

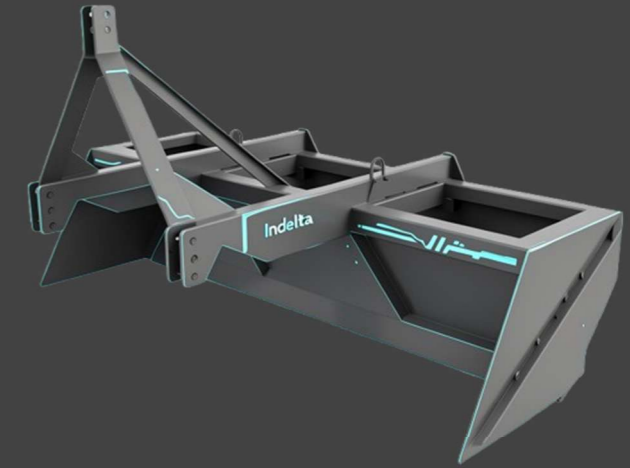

INDELTA EQUIPMENTS HYDRAULIC SCRAPERS



PROFESSIONAL SERIES Hydraulic Equipment

INDELTA hydraulic grader is a multifunctional service device, ideal for agricultural, forestry, and civil use.

It cleans roads, levels agricultural soil, and channels water.

It is such a versatile machine that it can even be used as a snowplow where professional snowplows cannot reach.

The working width ranges from 1.70 meters to 3.00 meters.

Standard Equipment:

- Hydraulic system equipped with two cylinders with simplified direction change:
 - horizontal and vertical
- 360° rotary blade
- Frame with a fully reinforced and height-adjustable 3rd point

Options:

- Control wheels with mechanical or hydraulic adjustment.

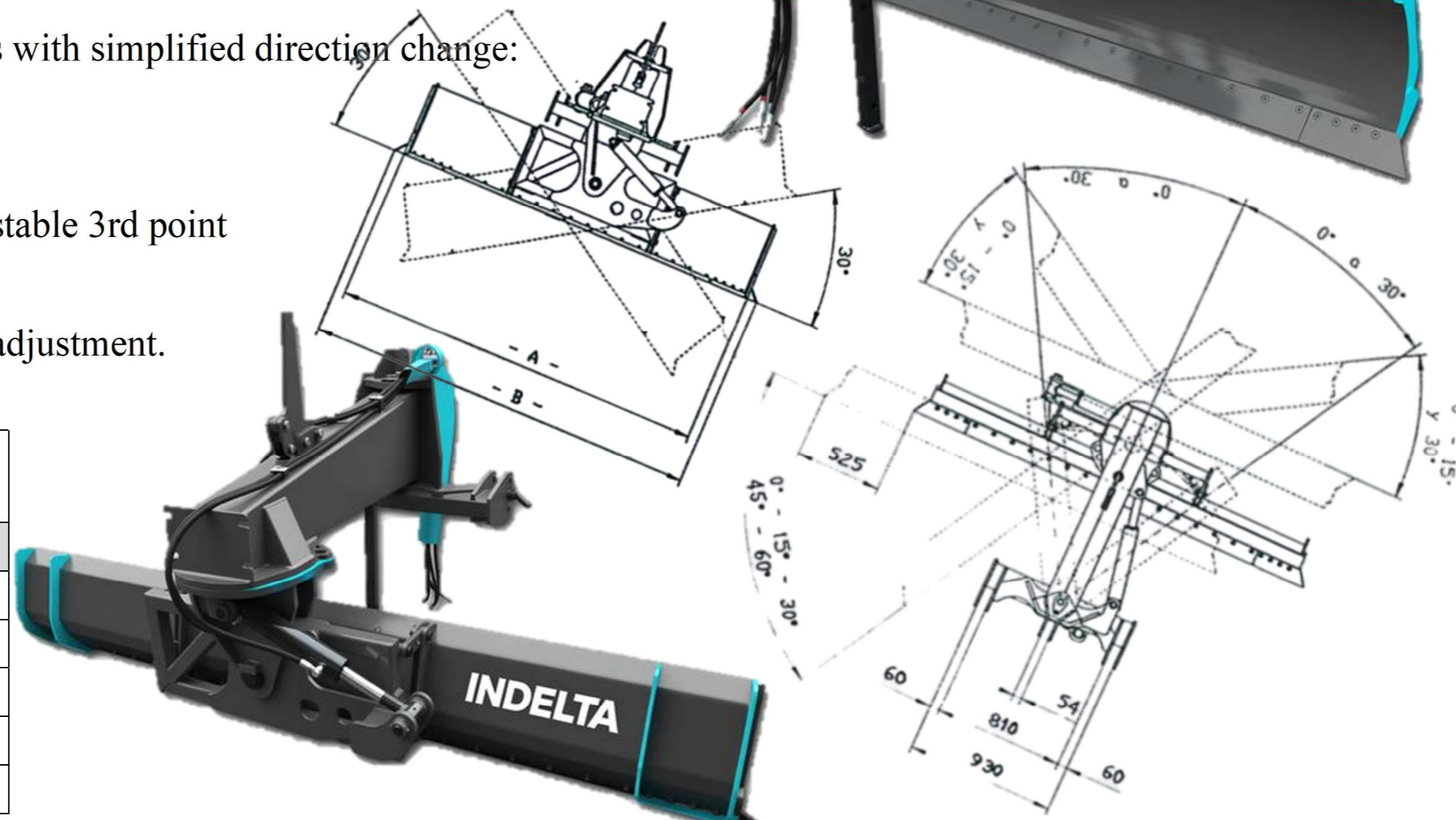

	Working Width	Transport Width	Power	Weight
MODEL	mm.	mm.	hp	kg
PLH-170	1700	1830	60-70	590
PLH-200	2000	2130	70-80	620
PLH-215	2150	2280	80-90	630
PLH-250	2500	2630	90-100	650
PLH-300	3000	3130	110-140	680

Additional Features: Displacement: Hydraulic, vertical and horizontal Blade: 360° reversible, Blade angle: ±30°, Blade height: 470 mm Frame angle: ±30°, Clearance: 600 mm.

INDELTA– Scrapers Service Machine

The Scrapers is a multifunctional service apparatus, designed for agricultural, forestry, and civil applications.

This highly adaptable machine can be used across agricultural land, field margins, road maintenance, sports surfaces, and industrial facilities.

Working Width: from 2.50 m to 3.50 m

Standard Equipment:

- Transport wheels
- 6 mm chassis
- 650 mm blade

Optional Features:

- Hydraulic drawbar
- Additional transport wheel kit (2 wheels)
- Three-point hitch for tractor (without wheels)
- Double three-point hitch for tractor (push and pull function, without wheels)
- Reinforced 8 mm chassis
- Signal lights



	Working Width	Transport Width	Power	Weight
MODEL	mm.	mm.	hp	kg
RF-2500	2500	2500	60-100	370
RF-3000	3000	3000	80-120	405
RF-3500	3500	3500	100-140	515

INDELTA– Hydraulic Scrapers – Maximum Efficiency with Minimal Effort



The hydraulic scrapers from Gascón International are ideal for vineyards, orchards, and civil applications. They are engineered to deliver maximum performance with minimal effort, offering enhanced capacity to move large volumes of soil across any type of terrain.

These scrapers collect excess soil from higher areas and transport it to lower zones, ensuring balanced ground leveling.

Operation Options (depending on model):

- Powered by the tractor's hydraulic system
- Remote-control operation

Key Features:

- Synchronized gate for precise opening according to work requirements
- Simple mechanism that eliminates the need for constant maintenance

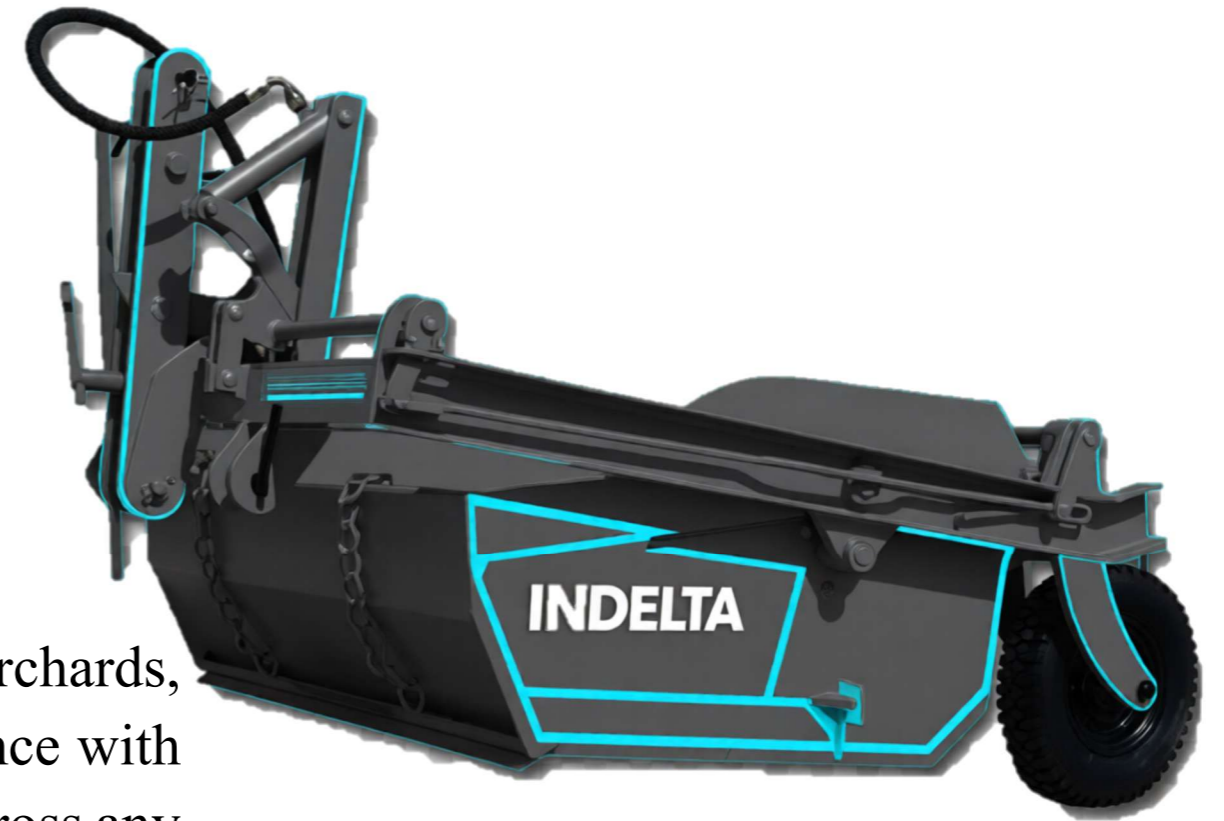



	Working Width	Transport Width	CAPACITY	Power	Weight	TIRES
MODEL	m.	mm.	M ³	hp	kg	
TS 5	1.00	1200	0.50	30-40	300	4.00 R8
TS 8	1.40	1600	0.80	45-55	500	6.00 R9
TV1	1.26	1500	1.00	40-50	800	6.00-16
TV5	1.81	2050	1.50	55-65	900	7.00-16
TH2500	2.22	2550	2.50	70-80	1650	265/70 R19.5
TH3000	2.30	2650	3.00	90	1700	265/70 R19.5
TH3500	2.35	2700	3.50	90-100	1850	285/70 R19.5
TH4000	2.40	2750	4.00	100-120	2500	385/65 R22.5
TH4500	2.50	2550	4.50	120-130	2800	385/65 R22.5
TH5000	2.50	2550	5.00	130-150	3000	385/65 R22.5

Additional Notes

- **Gate:** Mechanical; hydraulic in TH4500 & TH5000 (requires 3 double-acting outlets); mechanical with hydraulic release in TS models.
- **Tipping:** Mechanical with hydraulic release in TS; hydraulic in TV & TH models.
- **Blades:** Hardox wear-resistant steel in TH models.
- **Signal Lights:** Included in all models.

Applications:

- **TS Series:** Recommended for vineyards and orchards
- **TV Series:** Recommended for vineyards and orchards
- **TH Series:** Suitable for agricultural and civil use